



AES 5501 AUTOMOTIVE EMISSIONS SYSTEM FOR ISO 7637-2



The AES 5501 is a system of electronic and mechanical switches, an artificial network, and a unique control station designed for emissions testing to ISO 7637-2. Having gone through meticulous development and intensive beta testing, the AES 5501 contains unique features and uncompromising quality and conformity found nowhere else. Consisting of a four-part solution, the user has complete control over where, when and how the switches can be placed and controlled, including the necessary drive voltages for the relays.

The 100 A connectors are carefully placed and countersunk to allow precise cabling between the switches, the artificial network and test bench and allows for the electronic or mechanic switches to be placed at any point before or after the artificial network. Multiple switches may also be utilized at the same time as required. This careful attention to detail for switch placement and cable length means that numerous manufacturer standards can also be met. The AES 5501 features a rugged construction with unpainted underside for good earth contact, precise switching control and numerous monitoring locations. A counter for the relay and LED indicators for both electronic and mechanical switches are provided. The AES 5501 has temperature controlled fans for quiet operation and a thermal shutdown feature.

- Complete, compliant solution for ISO 7637-2 emissions testing
- Clean, reliable 100 A operation with very low voltage drop
- Industry standard relay footprint for a wide selection of relays (one 100 A relay included)
- Separate control station with automatic, manual or external triggering of the switching behavior
- Smaller switch enclosure for easier compliance to various cable-length requirements
- Totally redesigned AN with improved, fully compliant impedance curve
- Convenient measurement ports

Block diagram

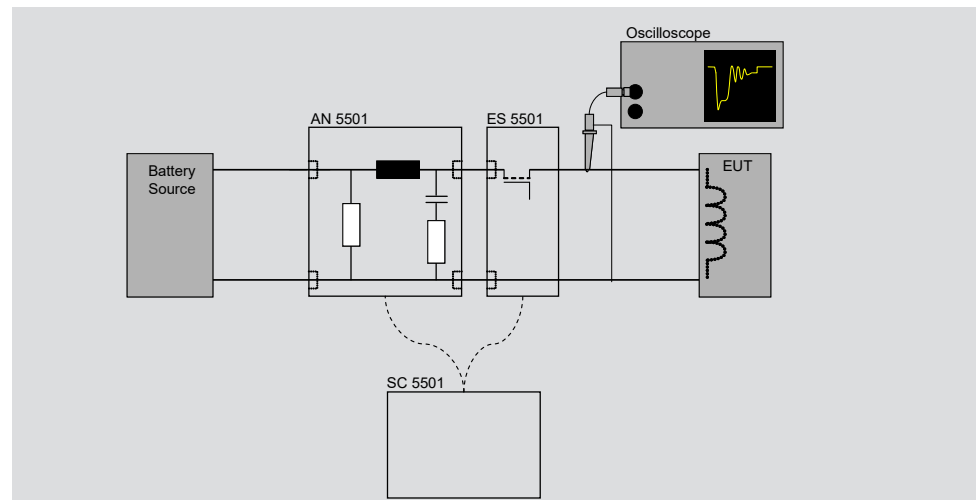

AES 5501 AUTOMOTIVE EMISSIONS SYSTEM FOR ISO 7637-2

Electronic switch - typical switching curve with test load

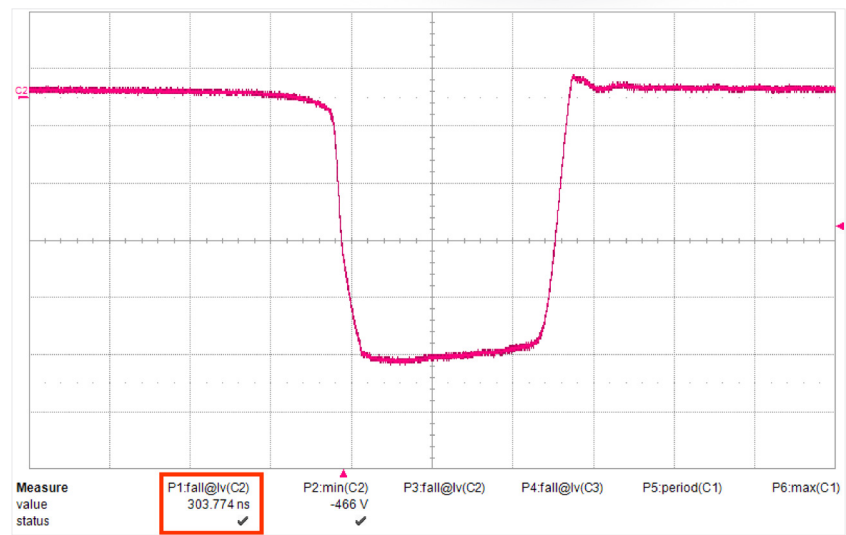

Typical impedance curve of AN 5501

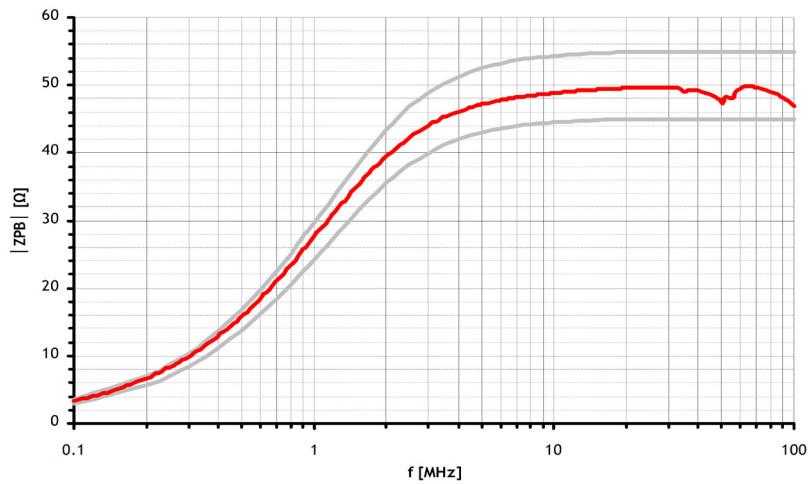

AES 5501 AUTOMOTIVE EMISSIONS SYSTEM FOR ISO 7637-2

Technical specifications

Complete system ¹⁾	
Battery current	100 A
Inrush current ²⁾	300 A for 200 ms
Battery voltage	0 to 60 VDC
Shunt resistor (R_s)	10, 20, 40, 120 Ω , Ext.
Trigger modes	External, internal, manual
Battery off time (t_{off})	10 ms – 10 s \pm (10% + 10 ms)
Battery on time (t_{on})	0.5 – 10.5 s \pm (10% + 10 ms)
Mains input voltage	85 – 264 VAC, 47 – 63 Hz
Available relay voltage	12, 24, 36 V (for 42 V applications)
Electronic switch	
Switching time Δt_s	300 ns \pm 20% ³⁾
Voltage drop	<1 V @ 25 A Typical 2.1 V @ 100 A
Transient voltage protection	440 V
Mechanical switch	
Type	Automotive relay
Contacts	High purity AgNi with no suppression across contacts
Voltage rating	> 400 V
Artificial network	
Inductance	5 μ H
Capacitance	0.1 μ F
Resistance	50 Ω
Impedance	As per ISO 7637-2 (see above impedance curve)
Connectors	100 A MC type, countersunk, 50 mm above ground plane
Housing	Stainless steel, unpainted underside, screw terminal and earth connections
Indicators	Counter on relay, LED indicator on controller for mechanical and electronic switches
Measurements ports	MS 5501, ES 5501 - directly connected to output AN 5501 – 5.6 k output impedance (to output connector – necessary for improved RF performance)
Physical dimensions (L x W x H)	ES 5501 125 x 125 x 125 mm MS 5501 125 x 125 x 125 mm AN 5501 340 x 270 x 205 mm
All tolerances \pm 10% unless otherwise noted.	

AES 5501

AUTOMOTIVE EMISSIONS SYSTEM FOR ISO 7637-2

- 1) Active, temperature dependant cooling. The ES 5501 is depending on duty cycle, approximately 3 minutes at 100 A with 100% duty cycle before the switch will be deactivated for cooling.
- 2) With supplied relay or electronic switch
- 3) With test load defined in ISO 7627-2. Purely resistive loads display typically in the range of a few microseconds.

Accessories

- Included: 4 x 60 mm cable, MC connector
- Included: 2 x 100 mm cable, MC connector
- Included: 4 x 0 mm pin, used when the housings will be pushed together (for zero millimeter distance)
- Included: INA 5032 – 100:1 high voltage probe compliant to ISO 7637-2
- Optional: INA 163 – Set of ten MC to banana adapters (only available in red)
- Optional: INA 5500-TL – Reference load ($R = 0.6 \Omega$, $L = 50 \mu\text{H}$)
- Optional: INA 5500-CK – Calibration kit for impedance curve verification (used for connection to network analyzer)
- Optional: MS 5501 – Additional unit for additional prepared relays
- Optional: Various inserts for MC 5501 for industry standard relay footprints

Switch housings are compact, optimized for conformity to strict layout requirements and offer ample earth contacts.



AMETEK CTS GmbH
 Sternenhofstrasse 15
 4153 Reinach
 Switzerland
www.teseq.com

© Aug. 2019 AMETEK CTS GmbH
 Specifications subject to change without notice.
 AMETEK CTS is an ISO-registered company. Its products are designed and manufactured under the strict quality and environmental requirements of the ISO 9001. This document has been carefully checked. However, AMETEK CTS does not assume any liability for errors or inaccuracies.

Teseq® is a registered trademark of AMETEK CTS GmbH

691-268C Aug. 2019

AMETEK®
 COMPLIANCE TEST SOLUTIONS

Teseq
 Advanced Test Solutions for EMC